

# MARINER



muebles  
GRUPO **INTERMOBEL**



muebles  
**INTERMOBEL**

# MARINER



> arte mediterráneo

muebles  
**INTERMOBEL**

Desde 1893, año de su fundación, **MARINER** viene creando lámparas y muebles. Sus originarios talleres artesanales, anteriores a la electrificación, han evolucionado a través del tiempo hasta la fábrica de hoy, dotada de modernas instalaciones.

La obra de su fundador, Enrique Mariner Gurrea, ha sido continuada a lo largo de los años manteniendo la más pura **tradición** gracias al constante afán de superación de cinco generaciones.

A lo largo de su dilatada actividad, desde hace más de cien años, la **creatividad** ha estado presente en la obra de MARINER.

Sus productos, desarrollados en el ámbito de iluminación y mobiliario, incorporan **diseños propios**, adaptando la innovación a las tendencias decorativas

del momento. Todo ello utilizando **materiales cuidadosamente seleccionados** y aplicando un riguroso proceso de acabados, que confieren una calidad internacionalmente reconocida, a todas y cada una de sus creaciones.

Una constante histórica de la firma MARINER, durante más de un siglo, viene siendo la pasión por la obra bien hecha.

Nuestros productos artesanos han sabido transmitir perfectamente su experiencia y sensibilidad, generación tras generación, compaginando los más tradicionales métodos con las modernas técnicas de fabricación, y **convirtiendo cada pieza creada en una auténtica obra de arte.**

# MARINER

m u e b l e s  
GRUPO **INTERMOBEL**



Since it was founded in 1893, **MARINER** has been creating lamps and furniture. The company's original workshops, dating from before the advent of electricity, have evolved over the years to answer the needs of changing times, equipped with modern installations.

Despite more than a century of progress, the spirit of the company founder, Enrique Mariner Gurrea, is still reflected in all product ranges, thanks to the way five successive generations have preserved the heritage of the past while incorporating the improvements of the present.

Throughout the history of the company, reaching back over one hundred years creativity has always been a major feature of MARINER works.

In the fields of both Furnishing and Lighting, MARINER products incorporate in-house designs, in which innovations are adapted to the latest trends in decoration. **All materials employed are carefully selected to ensure quality.** They undergo a rigorous finishing process which gives them the kind of quality MARINER is internationally known for.

A constant feature in the history of MARINER, reaching back for over a century, has always been a passion for quality craftsmanship.

Our master craftsmen have always managed to transmit their experience and sensitivity generation after generation, bringing traditional methods into unison with modern manufacturing techniques and **converting each individual piece into an authentic work of art.**



m u e b l e s  
GRUPO **INTERMOBEL**

# ATRIA

Mariner presenta su nueva colección ATRIA de tendencia contemporánea y con influencias del Art-Decó (que tiene su origen en los elementos innovadores del modernismo).

Esta colección se distingue por el refinamiento de sus acabados en nogal, realzando sus líneas, con revestimientos en cromo que perfilan la estructura del mueble.

Estas características dotan a ATRIA de una gran belleza y fuerza en el diseño, haciendola de una gran singularidad.

*Mariner presents its new collection ATRIA with a contemporary tendency and Art-Deco influence (which has its starting point in the innovative elements of the modernism)*

*This collection is distinguished by its refinement of its walnut finishes, arising its own lines, with chrome coating that streamlines its furnishing structure.*

*These attributes give to ATRIA a great beauty and powerful design, giving it a big singularity.*





muebles  
GRUPO **INTERMOBEL**





**INTERMOBEL**





GRUPPO  
**INTERMOBEL**



ATRIA  
La belleza en las formas.  
*The beauty of shapes.*



m u s  
**INTERMOBEL**



Vitrina con halógenos en su interior.  
*Cabinet with halogen lights in its interior.*



muebles  
GRUPO **INTERMOBEL**



muebles  
GRUPO **INTERMOBEL**



**ATRIA**  
Distinción con encanto.  
*Distiction with charm.*



GRUPO **INTERMOBEL**

# ATRIA

Diferente, apasionada.

*Different and passionate.*



GRUPO **INTERMOBEL**









muebles  
**INTERMOBEL**



mesa comedor / table

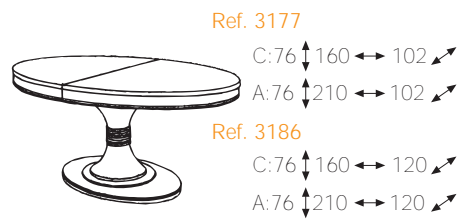

aparador / buffett

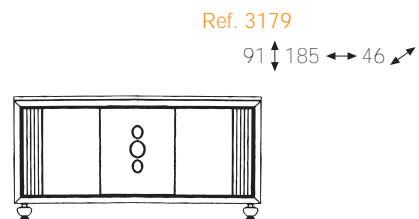

mesa comedor / table

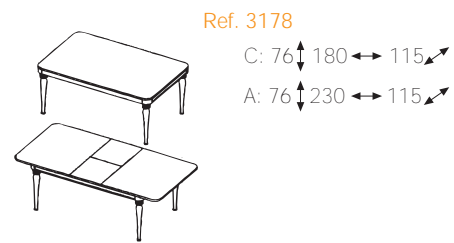

vitrina / vitrine

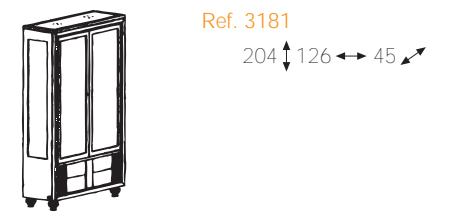

aparador / buffett

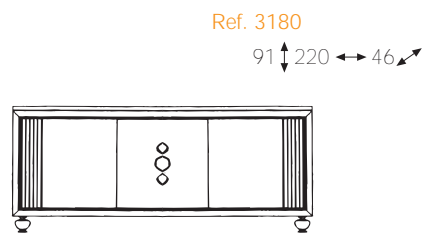

silla / chair



sillón / armchair



marco / mirror

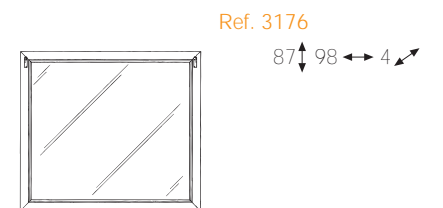

mesita noche / night table



cómoda / commode

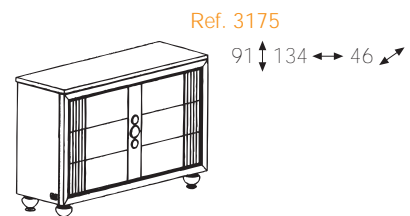

cabecero / head board

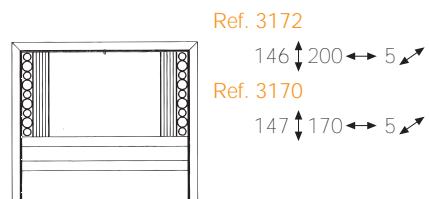

cabecero tapiz / head board

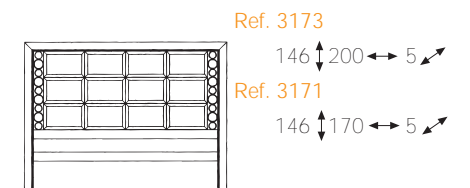



muebles  
**INTERMOBEL**



# ARGOS

Colección de mueble contemporáneo en la que destaca su diseño elegante y discreto de líneas rectas que combinan con formas curvas.

La marquetería queda integrada en perfecta armonía con la madera de haya y los acabados en cerezo y rareza de fresno, también destacan sus tiradores de bronce envejecido.

Todas estas características que son propias del saber hacer de la marca MARINER han hecho de la colección ARGOS un símbolo de calidad.

*Line of contemporary furniture in which emphasizes its elegant design and tactful straight lines combined with curve shapes.*

*The marquetry stays integrated in perfect harmony with the beech wood and cherry tree finishes and rareness ash tree. Even the aged bronze doorknobs are distinguished.*

*All these characteristics which are owned by the well making sense of the trade mark MARINER, have made the ARGOS collection a quality symbol.*

veles  
**INTERMOBEL**

Edificio Veles i Vents (Valencia)  
Comunidad Valenciana



muebles  
GRUPO **INTERMOBEL**



acabado argos  
*argos finished*



Muebles  
**INTERMOBEL**





**ARGOS**  
Lleno de detalles.  
*Full of details.*

Mesa extensible de fácil apertura.  
*Extensible table with easy opening.*



muebles  
GRUPO **INTERMOBEL**





**INTERMOBEL**

Vitrina incorpora luces halógenas en su interior.  
*Cabinet which incorporates halogen lights in its interior.*



muebles  
**INTERNOBEL**



acabado argos  
argos finished



muebles  
**INTERMOBEL**





es  
**INTERMOBEL**



acabado argos  
*argos finished*



muebles  
GRUPO **INTERMOBEL**

acabado argos  
argos finished



Muebles  
**INTERMOBEL**







**ARGOS**  
Sensual, apasionada.  
*Sensual and passionate.*

acabado argos  
*argos finished*



muebles  
**GRUPO INTERMOBEL**





acabado delfos  
delfos finished



GRUPPO **INTERMOBIL**

acabado argos  
argos finished



m v e b l e s  
GRUP  
**INTERMOBEL**





muebles  
GRUPO **INTERMOBEL**

mesa comedor / table

aparador / buffet

silla / chair

sillón / armchair

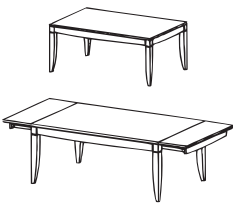

Ref. 2953

C: 76 ↑ 180 ↔ 115 ↘

A: 76 ↑ 260 ↔ 115 ↘

Ref. 2972

C: 76 ↑ 160 ↔ 105 ↘

A: 76 ↑ 230 ↔ 105 ↘

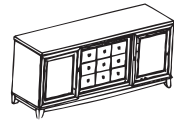

Ref. 2954

83 ↑ 220 ↔ 55 ↘

Ref. 2955

83 ↑ 185 ↔ 55 ↘

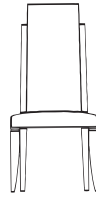

Ref. 2958

103 ↑ 48 ↔ 51 ↘

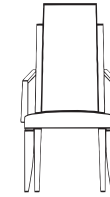

Ref. 2959

103 ↑ 48 ↔ 51 ↘

mueble T.V. / T.V. case

mesa lateral / side table

mueble T.V. / T.V. case

vitrina / vitrine

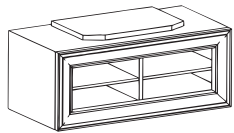

Ref. 2990

59 ↑ 120 ↔ 60 ↘

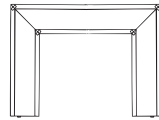

Ref. 2975

50 ↑ 70 ↔ 70 ↘

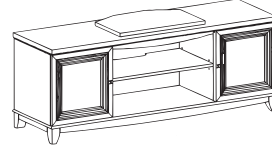

Ref. 2966

74 ↑ 185 ↔ 55 ↘

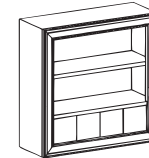

Ref. 2991

122 ↑ 120 ↔ 45 ↘

mesita noche / night table

estantería / shelves case

estantería con puertas / shelves case with doors

estantería / shelves case



Ref. 2980

60 ↑ 50 ↔ 35 ↘

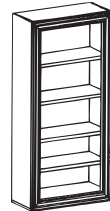

Ref. 2984

215 ↑ 100 ↔ 45 ↘

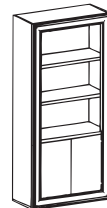

Ref. 2986

215 ↑ 100 ↔ 45 ↘

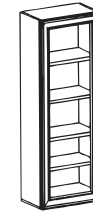

Ref. 2987

215 ↑ 75 ↔ 45 ↘

estantería con cajones / shelves case with drawers

vitrina / vitrine

cajonera / drawer furniture

chiffonier / chiffonier



Ref. 2988

215 ↑ 75 ↔ 45 ↘

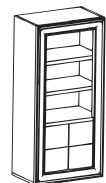

Ref. 2989

160 ↑ 75 ↔ 45 ↘

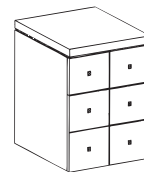

Ref. 2994

53 ↑ 45 ↔ 53 ↘

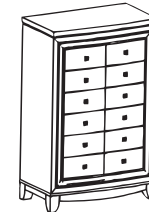

Ref. 2995

125 ↑ 80 ↔ 45 ↘



vitrina / vitrine

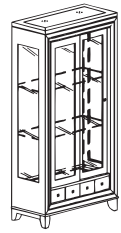

Ref. 2957

190 ↑ 95 ↔ 44 ↗

vitrina / vitrine

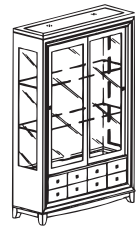

Ref. 2956.1

204 ↑ 135 ↔ 44 ↗

centro / coffee table

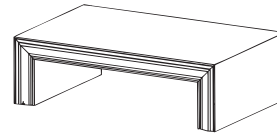

Ref. 2974

43 ↑ 140 ↔ 85 ↗

centro / coffee table

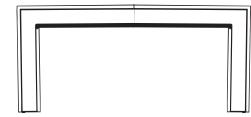

Ref. 2973

42 ↑ 105 ↔ 105 ↗

estantería / shelves case

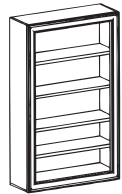

Ref. 2981

215 ↑ 130 ↔ 45 ↗

estantería con puertas / shelves case with doors

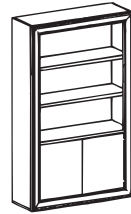

Ref. 2983

215 ↑ 130 ↔ 45 ↗

cabecero / head board

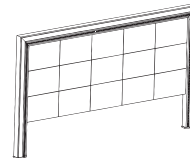

Ref. 2960

130 ↑ 200 ↔ 6 ↗

Ref. 2961

130 ↑ 170 ↔ 6 ↗

Ref. 2979

130 ↑ 155 ↔ 6 ↗

mesita noche / night table



Ref. 2962

60 ↑ 65 ↔ 35 ↗

mesa despacho / desk

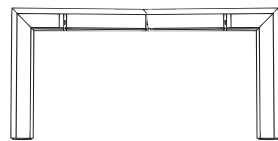

Ref. 2992

76 ↑ 160 ↔ 80 ↗

banqueta / stool



Ref. 2965

44 ↑ 94 ↔ 40 ↗

cómoda / commode

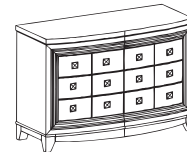

Ref. 2963

83 ↑ 120 ↔ 51 ↗

marco / mirror

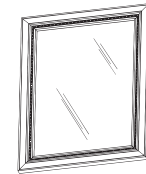

Ref. 2964

117 ↑ 89 ↔ 4 ↗



# BYBLOS



muebles  
**INTERMOBEL**



La colección de mueble contemporáneo "Byblos" mantiene el diseño del producto creado para satisfacer las tendencias en el mundo de la decoración.

La marca MARINER está siempre en constante renovación, para poder cubrir las necesidades del mercado, para ello cuenta con un gran equipo de diseñadores, decoradores y sobre todo de artesanos.

El producto ha sido fotografiado en la ciudad de Valencia. En casas de un alto diseño y singularidad en la que nuestros muebles están en perfecta armonía.

Los acabados, los propios de la marca MARINER, son cuidados minuciosamente durante todo el proceso artesano hasta el más mínimo detalle, como se puede apreciar en este caso en sus maderas en cerezo y las puertas en fresno olivato combinados con herrajes de bronce fundidos a la arena.

*The collection of contemporary furniture "Byblos" keeps the product design created to satisfy the tendencies in decoration world.*

*The trade mark MARINER is always in constant renewal, in order to cover all the market necessities, for these it has a great group of designers, decorators and over everything artisans.*

*The product has been photographed in Valencia city. In high level design and singularity houses in which our furnishing pieces are in perfect harmony.*

*The finishes, owned by the trade mark MARINER, are treated meticulously during all the artisan process until the less minimum detail, as can be appreciated in this case with its cherry tree woods and olived ash tree doors combined with sandy ruined bronze fittings.*



m u e b l e s  
**INTERMOBEL**

Playa de la Malvarrosa (Valencia)  
Comunidad Valenciana



GRUPA  
**INTERMOBEL**



BYBLOS  
Frescura romántica.  
*Romantic freshness.*



GRUPO **INTERNOBEL**



Mesa extensible  
Extensible table



GRUPPO **INTERMOBEL**







# BYBLOS

Delicados y con encanto.  
*Delicate and charm.*



GRUPO  
**INTERMOBEL**





GRUPPO **INTERMOBEL**





La combinación del cerezo y la rareza del fresno crea un contraste de claros y oscuros que armoniza la estancia según la luz.

*The combination of cherry tree and rareness ash tree creates a contrast with clear and darks which harmonize in the room depending on the light.*



GRUPO **INTERMOBEL**





muebles  
**INTERMOBEL**





Современные  
**INTERMOBEL**









INTERMOBEL





GRUPPO **INTERMOBEL**





GR  
**INTER** *HOME*



mesa comedor / table



Ref. 3071

C: 77 ↑ 180 ↔ 115 ↗

A: 77 ↑ 245 ↔ 115 ↗

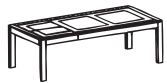

Ref. 3072

C: 77 ↑ 160 ↔ 105 ↗

A: 77 ↑ 225 ↔ 105 ↗

silla / chair



Ref. 3076

105 ↑ 48 ↔ 51 ↗

sillón / armchair



Ref. 3077

105 ↑ 48 ↔ 51 ↗

aparador / buffett

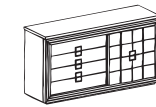

Ref. 3074

91 ↑ 170 ↔ 52 ↗

aparador / buffett

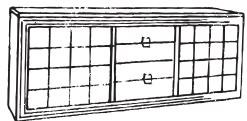

Ref. 3073

91 ↑ 220 ↔ 52 ↗

vitrina / vitrine



Ref. 3075

210 ↑ 130 ↔ 45 ↗

mueble T.V. / T.V. case

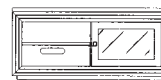

Ref. 3107

59 ↑ 130 ↔ 35 ↗

estantería / shelves case

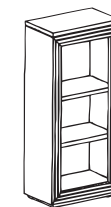

Ref. 3110

135 ↑ 60 ↔ 35 ↗

estantería / shelves case

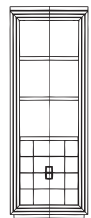

Ref. 3109

180 ↑ 68 ↔ 35 ↗

balda / shelf

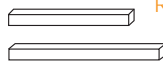

Ref. 3098

5 ↑ 60 ↔ 30 ↗



Ref. 3099

5 ↑ 130 ↔ 30 ↗

vitrina / vitrine

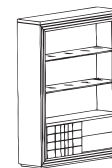

Ref. 3108

167 ↑ 130 ↔ 35 ↗

mueble T.V. / T.V. case

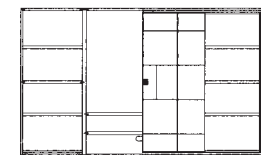

Ref. 3149

172 ↑ 276 ↔ 43 ↗

mesita noche / night table

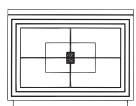

Ref. 3082

51 ↑ 65 ↔ 36 ↗

cabecero / head board

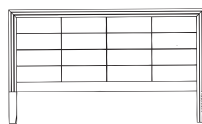

Ref. 3080

128 ↑ 198 ↔ 12 ↗

Ref. 3081

128 ↑ 168 ↔ 12 ↗

marco / mirror

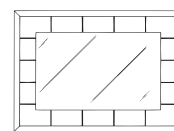

Ref. 3084

78 ↑ 110 ↔ 3 ↗

cama completa / bed

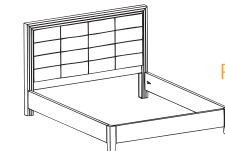

Ref. 3078

128 ↑ 198 ↔ 210 ↗

Ref. 3079

128 ↑ 168 ↔ 210 ↗

cómoda / commode

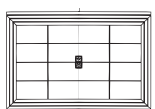

Ref. 3083

83 ↑ 120 ↔ 55 ↗



La colección ÁTICA destaca por la sencillez de sus líneas, en el diseño y la funcionalidad de las mismas, adaptándose a la perfección al nuevo concepto de hábitat actual.

La combinación del cerezo en tonos claros y oscuros ayudan a crear en el hábitat una sensación de calidez.

Los acabados, los propios de la marca Mariner, que cuidan minuciosamente todo el proceso artesano hasta el más mínimo detalle como se puede apreciar en los muebles y tiradores, realizados en bronce y decorados artesanalmente.

*ATICA collection is high lined by its simplicity lines, in the design and functionality, adapting to the perfection of the habitat new concept, nowadays.*

*The combination of the cherry tree in clear and dark tones, help to create in the habitat a warm sensation.*

*The finishes, owned by the trade mark MARINER , are treated meticulously during all the artisan process until the less minimum detail, as can be appreciated in the furniture pieces and doorknobs, made in bronze and artisan decoration.*





# ÁTICA



muebles  
GRUPO **INTERMOBEL**

Ciudad de la Ciencias (Valencia)  
Comunidad Valenciana





m u e b l e s  
GRUPO **INTERMOBEL**





muebles  
GRUPO **INTERMOBEL**





GRUPPO  
**INTERMOBEL**





Mesa de comedor extensible y de fácil manejo gracias a su sistema incorporador.  
*Extensible dining table and easy to use thanks to its built-in system.*



muebles  
**GRUPO INTERMOBIL**



# ATICA

Armonía, calidez, elegancia...  
Harmony, charm, elegance...



GRUPO  
**INTERMOBEL**





muebles  
**INTERMOBEL**



meubles  
GRUPPO **INTERMOBEL**





muebles  
**INTERMOBEL**



GRUPPO  
muebles  
**INTERMOBEL**





ATICA  
Belleza contemporánea.  
*Contemporary beauty.*



muebles  
**INTERMOBEL**





muebles  
GRUPO **INTERMOBEL**



mesa comedor / table

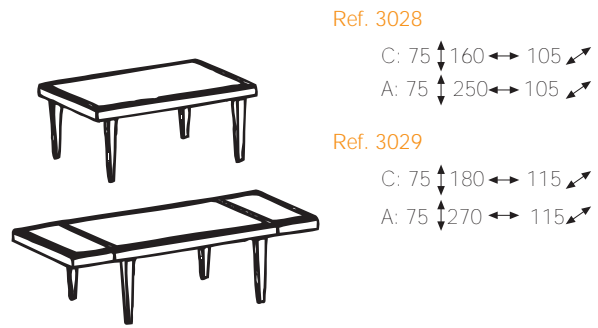

silla / chair

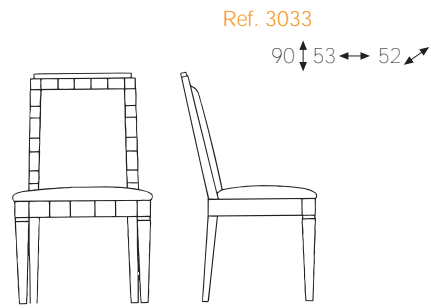

sillón / armchair

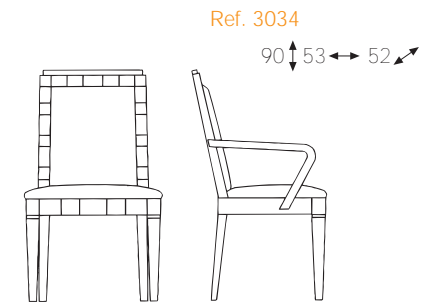

vitrina / vitrine

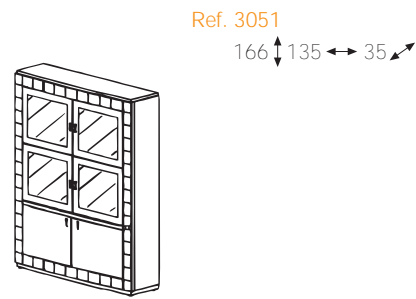

mueble T.V. / T.V. case

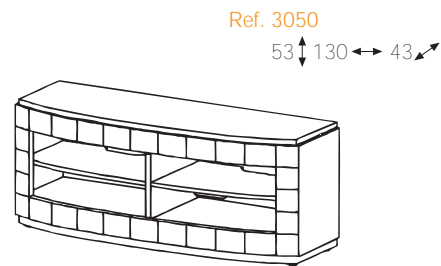

vitrina / vitrine

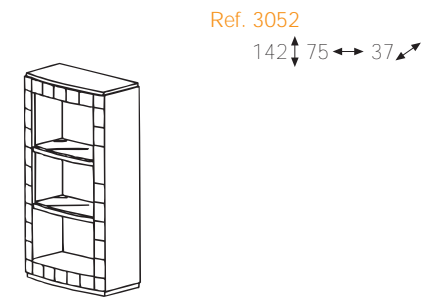

estantería / shelves case

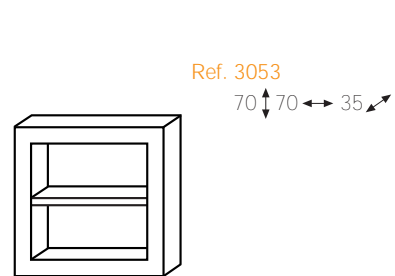

mesa centro / coffee table

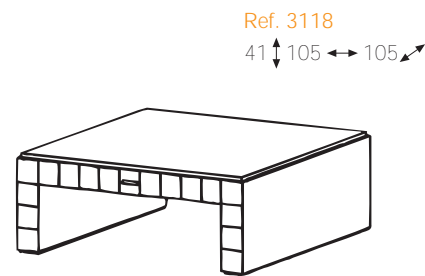

cajonera 1 cajón / furniture 1 drawer

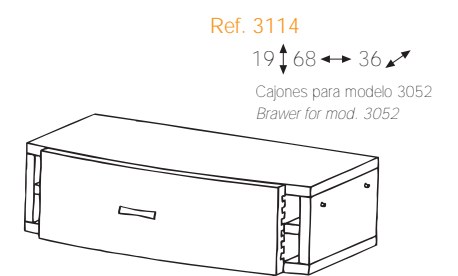



aparador / buffett

Ref. 3030

89 ↑ 180 ↔ 52 ↗

Ref. 3031

89 ↑ 220 ↔ 52 ↗

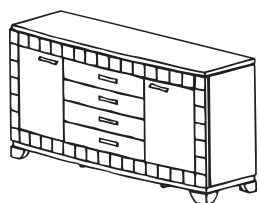

vitrina / vitrine

Ref. 3032

203 ↑ 133 ↔ 44 ↗

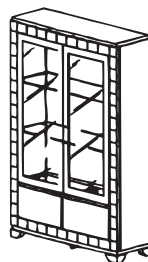

mesa centro / coffee table

Ref. 3037

41 ↑ 120 ↔ 70 ↗

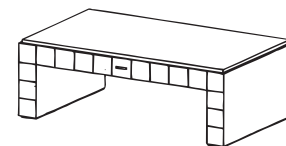

velador / side table

Ref. 3038

49 ↑ 60 ↔ 60 ↗

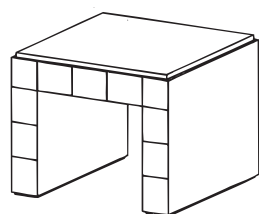

balda / shelf

Ref. 3054

6 ↑ 130 ↔ 28 ↗



Ref. 3055

6 ↑ 75 ↔ 28 ↗

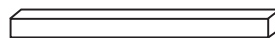

mueble T.V. / T.V. case

Ref. 3069

75 ↑ 185 ↔ 40 ↗

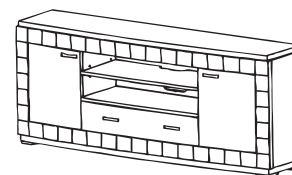

cajonera 2 cajones / furniture 2 drawers

Ref. 3113

38 ↑ 68 ↔ 36 ↗

Cajones para modelo 3052  
Drawer for mod. 3052

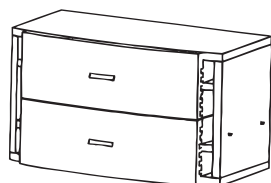

consola / console

Ref. 3035

97 ↑ 130 ↔ 47 ↗

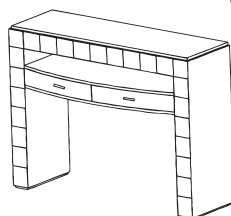

marco / mirror

Ref. 3036

115 ↑ 63 ↔ 3 ↗

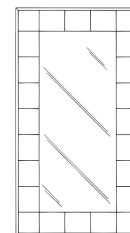



# Piezas Singulares

En el presente catalogo, y bajo el titulo genérico de Piezas Singulares, recopilamos y mostramos todos aquellos muebles complementarios que no pertenecen expresamente a una determinada colección.

Modelos verdaderamente importantes en unos casos, o pequeños muebles auxiliares en otros, en muy diferentes estilos y acabados, para muy diversas funciones, pero siempre con la sensibilidad y calidad que ya resultan característicos en todos nuestros productos.

muebles  
**INTERMOBEL**





## *Ocasional Furnitures*

*Under the generic title of occasional furniture, this catalogue showcases all our furniture pieces which do not belong to any particular collection.*

*In some cases these pieces are truly important models, and in other are smaller-sized occasional pieces. They come in very different styles and finishes, serving divers uses, but of course, they always reveal our traditional sensitivity and well-known quality of our products.*

muebles  
**INTERMOBEL**

Vista de Benidorm (Alicante)  
Comunidad Valenciana



mueble bar / bar

Ref. 3191

162↑ 103↔ 42↗

estantería / shelves case

Ref. 3192

190↑ 77↔ 36↗

cómoda / commode

Ref. 3193

92↑ 133↔ 57↗

meso centro / coffee table

Ref. 3196

46↑ 110↔ 110↗



GRUPPO  
**INTERMOBEL**





INTERMOBEL



cómoda / commode

Ref. 3193

92↑ 133↔ 57↗



INTERMOBEL



cómoda / *commode*

Ref. 2435

88 ↑ 138 ↔ 47 ↗



GRUPPO  
**INTERMOBILI**





**INTERWOBEL**





consola / *console*

Ref. 3187

87↑ 132↔ 42↗

mesa centro / *coffee table*

Ref. 3188

45↑ 115↔ 115↗

velador / *side table*

Ref. 3189

68↑ 65↔ 65↗

sillón / *armchair*

Ref. 3112

85↑ 70↔ 60↗

muebles  
GRUPO **INTERMOBEL**



cómoda / commode

Ref. 3167

92↑ 120 ↔ 50 ↗



muebles  
**INTERMOBEL**





cómoda / *commode*

Ref. 2388

90↑134↔41↗

m u e b l e s  
**INTERMOBEL**





muebles  
GRUPO **INTERMOBEL**





mesa despacho / desk

Ref. 2471

79↑ 169↔ 90↗

vitrina / vitrine

Ref. 2472

172↑ 75↔ 37↗

sillón confidente / armchair

Ref. 2474

115↑ 62↔ 58↗

sillón / armchair

Ref. 2473

110↑ 60↔ 58↗

muebles  
GRUPO **INTERMOBEL**





muebles  
**INTERMOBEL**





velador / *side table*

Ref. 2384

65 ↑ x 68 Ø

sillón / *armchair*

Ref. 2434

82 ↑ 78 ↔ 78 ↗

mesa centro / *coffee table*

Ref. 2383

47 ↑ 158 ↔ 92 ↗

muebles  
GRUPO **INTERMOBEL**



Muebles  
**INTERMOBEL**



mesa centro / *coffee table*

Ref. 3091

41↑130 ↔ 75 ↗

velador / *side table*

Ref. 3092

50↑60 ↔ 60 ↗

marco / *mirror*

Ref. 3104

70↑70 ↔ 5 ↗

consola / *console*

Ref. 3093

80↑130 ↔ 40 ↗



muebles  
**INTERMOBEL**

marco / *mirror*

Ref. 3105

5 ↗ Ø 70



consola / console

Ref. 3102

80 ↑ 130 ↔ 38 ↗



GRUPPO **INTERMOBILI**



butaca / armchair

Ref. 3047

93 ↑ 70 ↔ 66 ↗



muebles  
**INTERMOBEL**

consola / console

Ref. 3044

80↑ 140↔ 40↗



GRUPPO **INTERMOBEL**



centro / coffee table

Ref. 3045

42 ↑ 100 ↔ 100 ↗



velador / side table

Ref. 3046

45 ↑ 60 ↔ 60 ↗



centro / coffee table

Ref. 3119

42 ↑ 140 ↔ 75 ↗



muebles  
**INTERMOBEL**



m u e cómoda / commode

Ref. 986

**INTERMOBEL**

A: 101 ↓ 140 ↔ 75 ↗

C: 101 ↓ 124 ↔ 55 ↗





m u e b canterano / vitrine

Ref. 2527

2171 144 45

**INTERMOBEL**





GRUPO muebles **INTERMOBEL**



índice / *index*

muebles  
GRUPO **INTERMOBEL**

Playa de la Malvarrosa (Valencia)  
Comunidad Valenciana



# índice / index

ref.:	colección	página	ref.:	colección	página	ref.:	colección	página
986	P. SINGULARES	86	2961	ARGOS	28	3028	ÁTICA	53-54-55
2383	P. SINGULARES	78-79	2962	ARGOS	28	3029	ÁTICA	53-54-55
2384	P. SINGULARES	78	2963	ARGOS	27-29	3030	ÁTICA	54-55-62
2388	P. SINGULARES	75	2964	ARGOS	27-29	3031	ÁTICA	54-55-62
2434	P. SINGULARES	79	2965	ARGOS	28	3032	ÁTICA	54
2435	P. SINGULARES	71	2966	ARGOS	26	3033	ÁTICA	53-54-55
2471	P. SINGULARES	76-77	2972	ARGOS	20	3034	ÁTICA	53-54-55
2472	P. SINGULARES	76-77	2973	ARGOS	24	3035	ÁTICA	63
2473	P. SINGULARES	76-77	2974	ARGOS	25	3036	ÁTICA	63
2474	P. SINGULARES	76-77	2975	ARGOS	24	3037	ÁTICA	56
2527	P. SINGULARES	87	2979	ARGOS	28	3038	ÁTICA	61
2953	ARGOS	20	2980	ARGOS	29	3044	P. SINGULARES	84
2954	ARGOS	19-21	2987	ARGOS	30	3045	P. SINGULARES	85
2955	ARGOS	19-21	2989	ARGOS	23	3046	P. SINGULARES	85
2956	ARGOS	22	2990	ARGOS	23	3047	P. SINGULARES	83
2957	ARGOS	21	2991	ARGOS	23	3050	ÁTICA	56-57
2958	ARGOS	20-21	2992	ARGOS	30-31	3051	ÁTICA	56
2959	ARGOS	20-21	2994	ARGOS	31	3052	ÁTICA	57
2960	ARGOS	28	2995	ARGOS	29	3053	ÁTICA	58





ref.:	colección	página	ref.:	colección	página	ref.:	colección	página
3054	ÁTICA	58	3093	P. SINGULARES	81	3174	ATRIA	12-13-14
3055	ÁTICA	58	3098	BYBLOS	42	3175	ATRIA	13
3069	ÁTICA	60	3099	BYBLOS	42	3176	ATRIA	13
3071	BYBLOS	37-38	3102	P. SINGULARES	82	3177	ATRIA	7-8
3072	BYBLOS	37-38	3104	P. SINGULARES	81	3178	ATRIA	11
3073	BYBLOS	70	3105	P. SINGULARES	81	3179	ATRIA	7-8-10
3074	BYBLOS	43	3107	BYBLOS	42	3180	ATRIA	7-8-10
3075	BYBLOS	39	3108	BYBLOS	41	3181	ATRIA	9
3076	BYBLOS	37-38	3109	BYBLOS	42	3182	ATRIA	7-8
3077	BYBLOS	37-38	3110	BYBLOS	42	3183	ATRIA	9
3078	BYBLOS	46-47	3112	P. SINGULARES	72-73	3186	ATRIA	7-8
3079	BYBLOS	46-47	3118	ÁTICA	61	3187	P. SINGULARES	72
3080	BYBLOS	46-47	3119	P. SINGULARES	85	3188	P. SINGULARES	72-73
3081	BYBLOS	46-47	3149	BYBLOS	44	3189	P. SINGULARES	72-73
3082	BYBLOS	46-47	3167	P. SINGULARES	76	3191	P. SINGULARES	68
3083	BYBLOS	48	3170	ATRIA	12	3192	P. SINGULARES	69
3084	BYBLOS	48	3171	ATRIA	13	3193	P. SINGULARES	68-70
3091	P. SINGULARES	80	3172	ATRIA	12	3196	P. SINGULARES	68-69
3092	P. SINGULARES	80	3173	ATRIA	13			

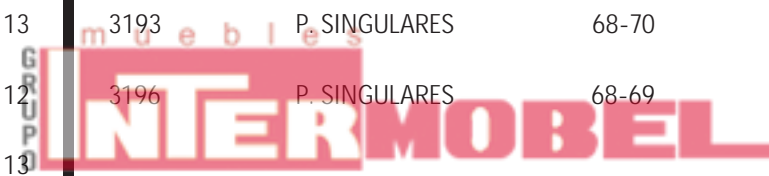

# MARINER

muebles  
**INTERMOBEL**





muebles  
**INTERMOBEL**